

TO-126 Plastic-Encapsulate Transistors

FEATURES

- Low Voltage
- High Current
- TRANSISTOR (NPN)

MECHANICAL DATA

- Case style:TO-126 molded plastic
- Mounting position:any

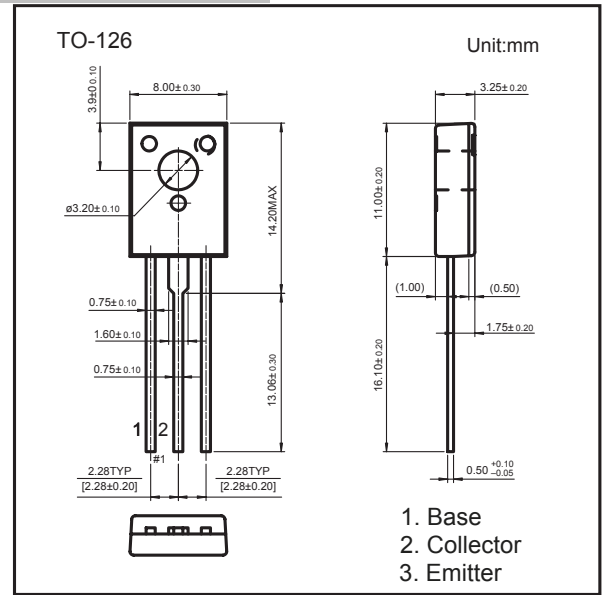

MAXIMUM RATINGS AND CHARACTERISTICS

@ 25°C Ambient Temperature (unless otherwise noted)

Symbol	Parameter	Value	Unit
V_{CB0}	Collector-Base Voltage	50	V
V_{CEO}	Collector-Emitter Voltage	50	V
V_{EBO}	Emitter-Base Voltage	5	V
I_C	Collector Current	3	A
P_C	Collector Power Dissipation	1	W
$R_{\theta JA}$	Thermal Resistance From Junction To Ambient	125	°C/W
T_j	Junction Temperature	150	°C
T_{stg}	Storage Temperature	-55~+150	°C

ORDERING INFORMATION

Part Number	Package	Packing Method	Pack Quantity
2SD886	TO-126	Bulk	200pcs/Bag
2SD886-TU	TO-126	Tube	60pcs/Tube

Parameter	Symbol	Test conditions	Min	Typ	Max	Unit
Collector-base breakdown voltage	$V_{(BR)CBO}$	$I_C=100\mu A, I_E=0$	50			V
Collector-emitter breakdown voltage	$V_{(BR)CEO}$	$I_C=5mA, I_B=0$	50			V
Emitter-base breakdown voltage	$V_{(BR)EBO}$	$I_E=100\mu A, I_C=0$	5			V
Collector cut-off current	I_{CBO}	$V_{CB}=50V, I_E=0$			1	μA
Emitter cut-off current	I_{EBO}	$V_{EB}=3V, I_C=0$			1	μA
DC current gain	$h_{FE(1)}$	$V_{CE}=2V, I_C=20mA$	100			
	$h_{FE(2)}$	$V_{CE}=2V, I_C=1A$	100		400	
Collector-emitter saturation voltage	$V_{CE(sat)}$	$I_C=2A, I_B=200mA$			0.5	V
Base-emitter saturation voltage	$V_{BE(sat)}$	$I_C=2A, I_B=200mA$			2	V
Collector output capacitance	C_{ob}	$V_{CB}=10V, I_E=0, f=1MHz$		45		pF
Transition frequency	f_T	$V_{CE}=5V, I_C=100mA$		80		MHz

*Pulse test: pulse width $\leq 300\mu s$, duty cycle $\leq 2.0\%$.

Marking	D886
---------	------